

# Intercept® ULTRA *Blackline* Simulation Model

**For More Information,  
Contact Chris Wale**

**GED Integrated Solutions**

Business Centre  
Forum House,  
Stirling Road  
Chichester  
West Sussex  
PO19 7DN, UK

Fax: +44 (0) 1243 786930  
Mobile: +44 (0) 781-577-6089

Email: [cwale@geduk.com](mailto:cwale@geduk.com)  
Web: [www.geduk.com](http://www.geduk.com)

**For THERM**

- ✓ Spacer wall thickness: ULTRA material = 0.195mm
- ✓ Thermal conductivity: ULTRA material = 13.63 W/mK  
Desiccant = 0.29 W/mK  
Sealant = 0.24 W/mK
- ✓ Spacer should be below sight line
- ✓ All dimensions in millimeters

***Accurate* Geometry**

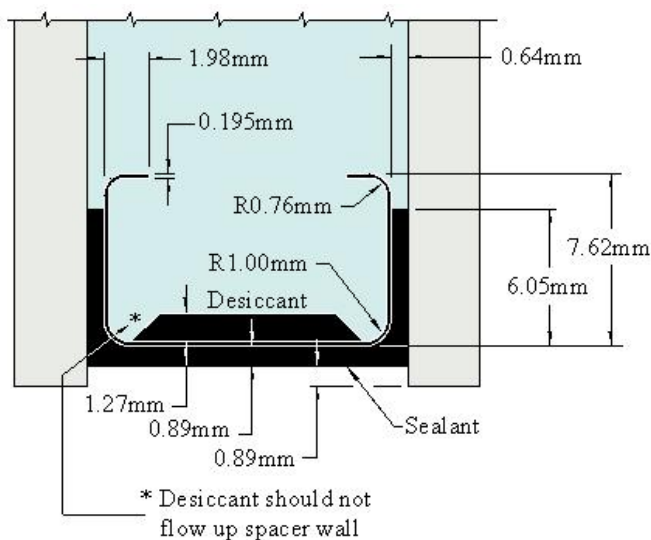

***Inaccurate* Geometry**

